

# Model 110-150

## Double Reduction Planetary Gear Reducer

### Flange Mount

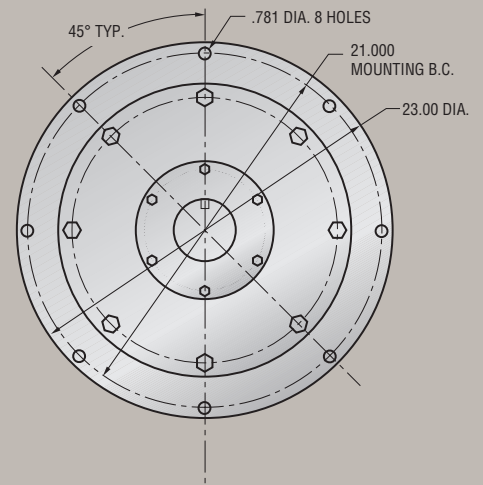
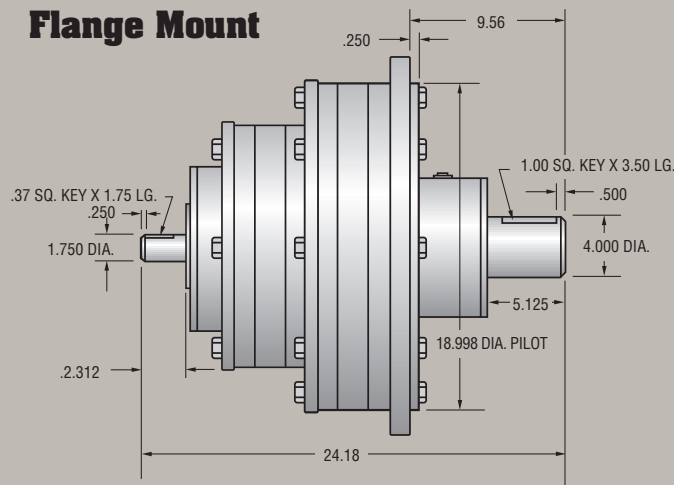

### Foot Mount

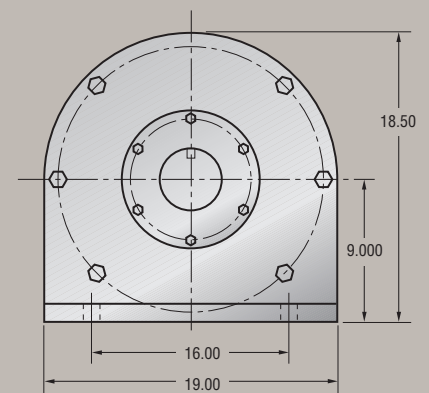
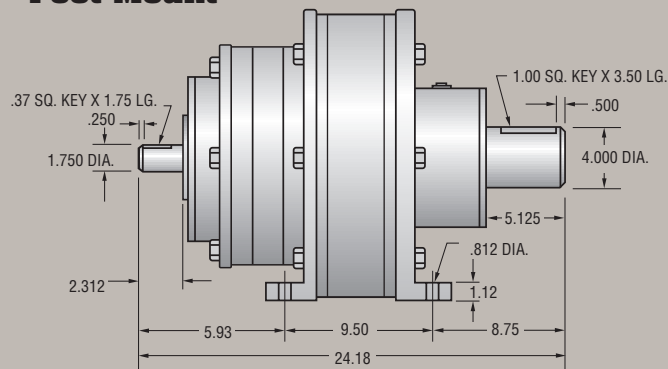

### Flange or Foot Mount w/SAE or NEMA Input

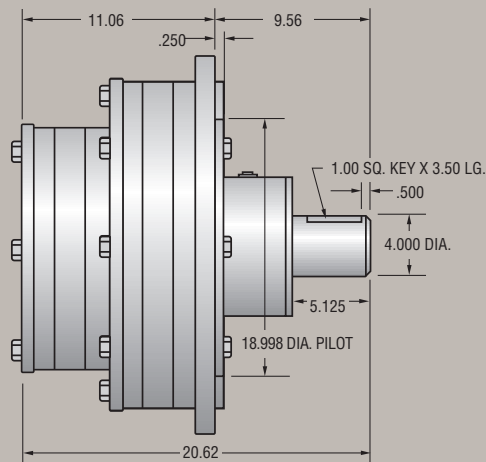

#### NEMA Electric Motor Direct Mount

"C" face direct couple of motor to speed reducer. No need for coupling or special motor mounts.

#### SAE Hydraulic Motor Direct Mount

2 bolt or 4 bolt direct couple of hydraulic motor to speed reducer. No need for coupling or special motor mounts.



*Byrne*  
**Gear Corporation  
of America**

- Planetary speed reducers
- High-speed increasers
- Custom design geared products

*"The Problem Solver"*

# Model 110-150

## Double Reduction Planetary Gear Reducer

Planetary Assembly	Ratios	OUTPUT HORSE POWER RATINGS (Adjusted for Thermal Efficiencies)						
		INPUT R.P.M.						
		100	580	720	870	1170	1430	1750
EE	9.00	23.89	81.79	95.15	108.63	133.66	153.82	177.18
EA	10.50	19.50	66.74	77.65	88.65	109.07	125.52	144.58
EB	12.00	17.46	59.75	69.51	79.36	97.65	112.37	129.44
AA	12.25	17.50	59.91	69.70	79.58	97.92	112.68	129.79
CE	13.00	18.47	63.23	73.56	83.98	103.33	118.91	136.97
AB	14.00	15.67	53.64	62.40	71.24	87.66	100.88	116.20
CA	15.15	15.07	51.59	60.03	68.53	84.32	97.04	111.77
BB	16.00	14.27	48.85	56.83	64.88	79.84	91.88	105.83
CB	17.33	13.49	46.19	53.74	61.35	75.49	86.87	100.06
DE	18.00	14.71	50.35	58.57	66.87	82.28	94.69	109.07
CC	18.78	9.47	32.41	37.70	43.04	52.96	60.95	70.20
DA	21.00	12.00	41.08	47.80	54.57	67.14	77.27	89.00
DB	24.00	10.75	36.78	42.79	48.85	60.11	69.18	79.68
DC	26.00	7.54	25.81	30.02	34.27	42.17	48.53	55.90
DD	36.00	5.77	19.74	22.97	26.22	32.27	37.13	42.77

Ratings based upon uniform steady and moderate shock loading. See load factor chart for details.

OUTPUT SHAFT RADIAL (overhung) LOAD CAPACITIES (at output r.p.m.)								
R.P.M.	10	20	30	50	100	200	300	500
Radial Capacity (lbs.)	20,000	16,000	14,000	12,000	10,000	9,500	8,000	6,500

OUTPUT SHAFT THRUST LOAD CAPACITIES (at output r.p.m.)								
R.P.M.	10	20	30	50	100	200	300	500
Thrust Capacity (lbs.)	36,209	28,997	26,051	23,344	18,155	14,750	13,059	11,200

**OUTPUT SHAFT MAXIMUM CONTINUOUS TORQUE CAPACITY:** 100,780 lb./inches  
**OUTPUT SHAFT INTERMITTENT TORQUE CAPACITY:** 201,560 lb./inches  
**WEIGHT:** 600 lbs.  
**RATING SYSTEM:** All Ratings Based Upon American Gear Manufacturers' Association Standards



*Byrne*

*"The Problem Solver"*

Part of The Byrne Group

Copyright © Byrne Gear Corporation of America  
 Printed in U.S.A. 697

### GEAR CORPORATION OF AMERICA

301 Byrne Gear Drive  
 P. O. Box 1789  
 Mansfield, Ohio 44901  
 Telephone: (419) 522-GEAR(4327)  
 Fax: (419) 525-2386  
 E-mail: byrne@byrnegroup.com  
 Visit our web site at: www.byrnegroup.com